

user manual

Compact Scroller CS70



Pani

The Company for Stage Lighting and Projection

# CONTENTS

	Page
<b>1) Dimension Drawing</b> .....	2
<b>2) Position Drawing and Legend</b> .....	2
<b>3) Mounting the Scroller on a PANI-Projector</b> .....	3
3.1) Mounting on 2,5 kW Projectors of the "Compact" and "CT"-Series.....	3
3.2) Mounting on 4 kW Projectors of the "Compact" and "CT"-Series.....	3
3.3) Mounting on the 6 kW Projectors BP 6 Gold II and BP 6 GT.....	4
3.4) Adapter System of Projection Lenses.....	4
3.5) Mounting the optional Dimming Shutter / PCS.....	5
3.6) <b><i>Important notes before starting projection</i></b> .....	5
<b>4) Controlling the Scroller</b> .....	5
4.1) Preparing the Film for standard working and for working with frames.....	5
4.2) Communication Area.....	6,7,8
4.3) DMX-512 Standard Protocol.....	8,9
4.4) The PC Mode and Automatic.....	9
4.5) The Pani Scene Mode.....	9
<b>5) Using Frames</b>	
5.1) General Information about Frames.....	10
5.2) Controlling Frames.....	10
5.3) Marks on the Film.....	11
5.4) Frames in Use .....	11
<b>6) The Scroller Module (Cassette) .....</b>	<b>11</b>
<b>7) Basic Unit as Delivered .....</b>	<b>12</b>
<b>8) Accessories .....</b>	<b>12</b>
<b>6) Technical Data .....</b>	<b>13</b>

### 1) Dimension Drawing

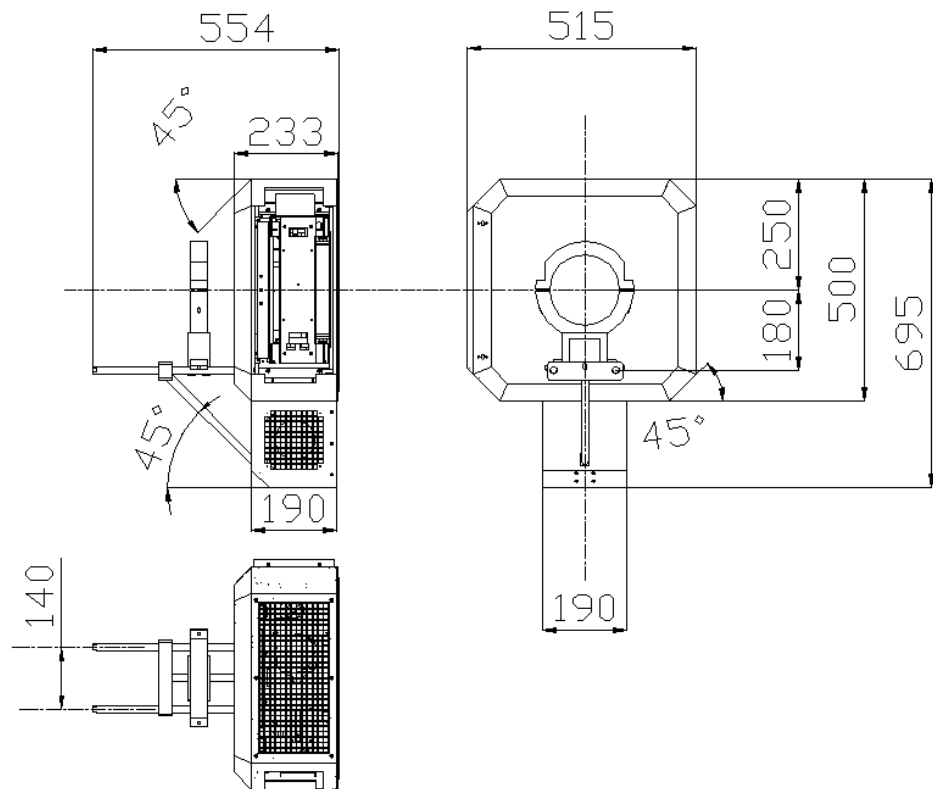

### 2) Position Drawing

#### Legend

- (1) Housing
- (2) Communication Area
- (3) Main Switch
- (4) Connection Sockets  
(1x 0-10V,  
2x numerical output)
- (5) Supporting Rod
- (6) Accessory Bearing Rods
- (7) Objective Mounting Ring
- (8) Ventilation Grids
- (9) Removable Scroller Unit
- (10) Lock Nut
- (11) Electrical Supporting Plug

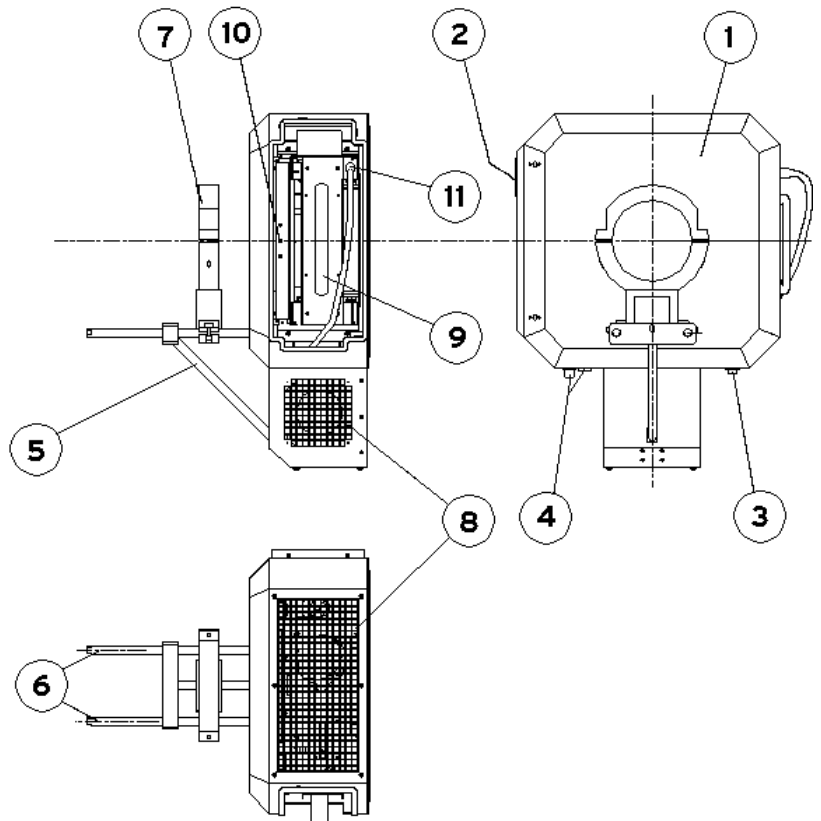

### 3) Mounting the Scroller on a PANI-Projector

provided for BP2,5Compact, BP2,5CT, BP4Compact, BP4CT, BP6GoldII and BP6GT

#### ***Preparing the Projector for mounting:***

For mounting the Scroller on a projector, you first have to dismount the following parts of the projector

- 1) The Ventilator for Slide Cooling
- 2) The Guide Roller for the Slide Carrier
- 3) Slide Carrier Locking Pin

#### ***Preparing the Scroller for mounting:***

- 1) Put out the Removable Scroller unit (9) after opening the Lock Nut (10)
- 2) Dismount the Standard mounting plate by unlocking the four wing nuts inside the scroller housing.

**Note:** The loading of the film into the Scroller Unit you'll find in the delivered "**Quick reference** for loading the film into a CS 70 scroller unit"

#### **3.1) Mounting on 2,5 kW Projectors of the "Compact" and "CT"-Series**

- 1) Dismount the Objective Support Bolts (Turning the front plate of the projector enables dismounting the hexagonal socket head screws)
- 2) Mount the standard mounting plate by using the delivered countersunk hexagonal socket head screws (DIN 7991M8x25).
- 3) Mount the housing of the scroller (1) by using the four wing nuts
- 4) Insert the the Removable Scroller unit (9), lock the nut and connect the Electrical Supporting Plug (11) with the socket of the Scroller unit.
- 5) Plug in the delivered dummy plug for using the projector without standard cooling fan

#### **3.2) Mounting on 4 kW Projectors of the "Compact" and "CT"-Series**

- 1) Dismount the Objective Support Bolts (Turning the front plate of the projector enables dismounting the hexagonal socket head screws)
- 2) Disconnect the projector from the electrical source, open the lid of the housing. Replace the Adjustable Clamp Lever for Front Plate by the delivered hexagonal screw (DIN 933 M8x30)
- 3) Mount the standard mounting plate by using the delivered countersunk hexagonal socket head screws (DIN 7991M8x25).
- 4) Mount the housing of the scroller (1) by using the four wing nuts
- 5) Insert the Removable Scroller unit (9), lock the nut and connect the Electrical Supporting Plug (11) with the socket of the Scroller unit.
- 6) Plug in the delivered dummy plug for using the projector without standard cooling fan (otherwise ignition would not be possible).

### 3.3) Mounting on BP 6 Gold II or BP 6 GT

- 1) Dismount the four Objective Support Brackets.
- 2) Mount the delivered Scroller Support Brackets like shown in the adjoining picture, but fasten only the two at the button
- 3) Mount the housing of the scroller (1) by using the four wing nuts and then fasten the screws of the brackets on top (to correct tolerances)
- 4) Insert the Removable Scroller unit (9), lock the nut and connect the Electrical Supporting Plug (11) with the socket of the Scroller unit.

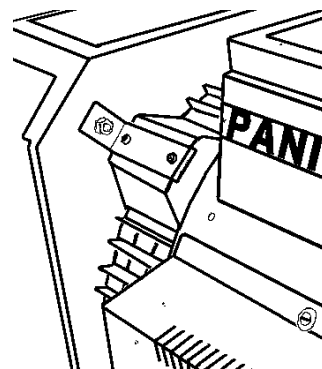

### 3.4) Adapter System of Projection Lenses

Using projection lenses of focal lengths over 27cm, may produce a scattered light, which may be unwanted in some cases.

Therefore a special modular bellows system is provided to combine the projection lens with the scroller housing. In the case of necessity, please contact our staff of Service and Support.

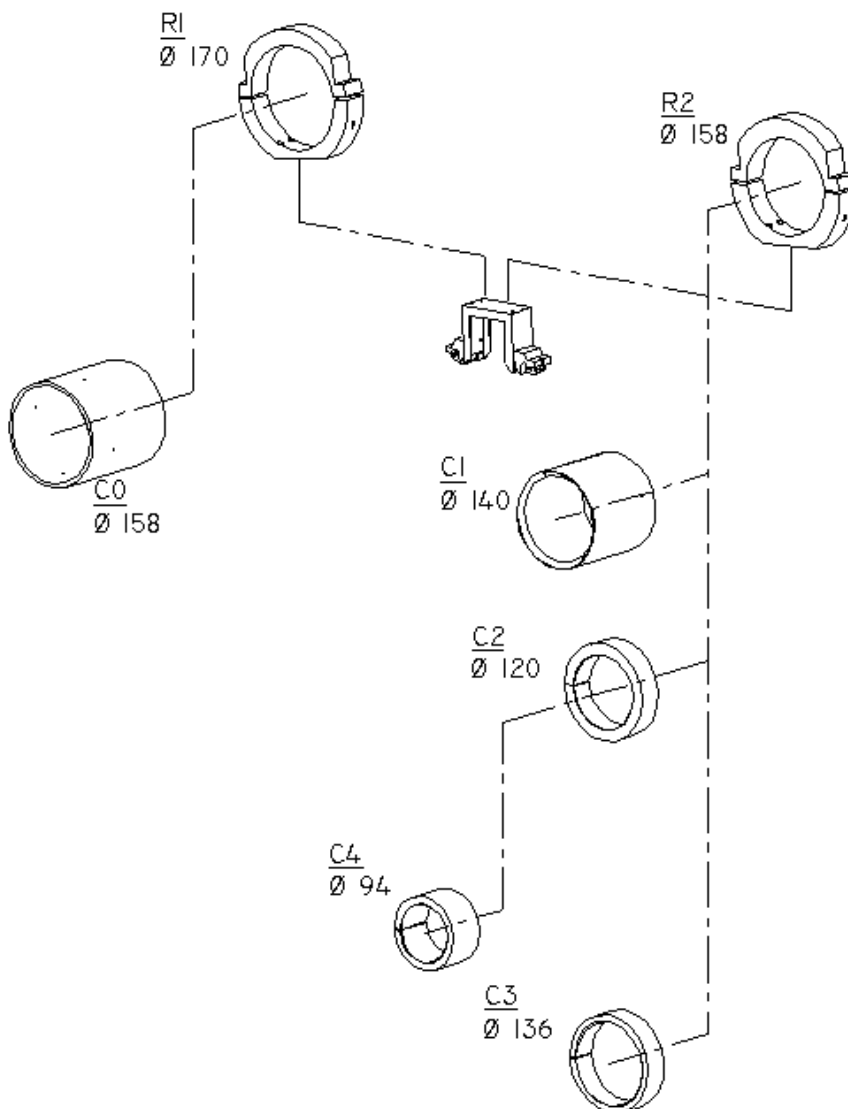

**Note:**

For using the motor driven focus unit (O.C. 12045) special mounting rings instead of R1 and R2 are used!

**Table of projection lenses and adapters:**

Lens	11cm	13,5cm	18cm	22cm	27cm	33cm	40cm	50cm	60cm
Adapter	R1+C0	R1+C0	R2+C1	R2+C1	R2+C1	R2+C2+C4	R2+C2	R2+C3	R1+C0

### 3.5) Mounting the optional Dimming Shutter / PCS

The mounting and driving of the Dimming Shutter / PCS (G 405/ PCS, Order Code 22702) is very simple:

- 1) Dismount the standard mounting brackets of the dimming shutter
- 2) Mount the delivered adapter unit, which is shown in the adjoining figure with the delivered screws and mount the unit to the two Accessory Bearing Rods (6)

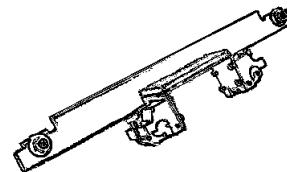

- 3) Connect (0-10V) the scroller (3pin-XLR connection socket (4)) with the control box of the shutter by using the delivered cable  
The dimming shutter uses DMX-channel 6 (see more in the documentation of controlling the scroller)

- 4) Connect dimming shutter and the control box as normal.

### 3.6) Important Notes before starting projection:

Before Starting projection with the Compact Scroller CS 70 it is necessary to recognise the following Information:

*The fan of the Scroller is independently working, so*

- **connect the plug to the 230V - source and switch on the Scroller first (before you start the projector) Then start the projector.**
- **After ignition, switch on the scroller electronic. If you do it before ignition, the electronic may be disturbed by the ignition process.**
- **After operation (when the projector is switched off) keep the scroller fan running for at least 3 minutes to save the film against heat tailback.**

## 4) Controlling the Scroller

### 4.1) Preparing the Film for standard working and for working with frames (more precise)

The clear film parts at the beginning and the end of the scroller film are marked with a very thin high reflective tape. They are delivered premounted in the scroller unit. There is one cut, where you can split the clear film and mount the projection film between (take care of the right orientation, it's the same as in standard slide projection!) For loading the film, see the delivered quick reference. *As the film guiding has a free area of 18cm the cut film has to be with a width of only 17,5-17,8cm to guarantee optimal function.*

For very accurate driving (up to 0,05mm repeatable precision) it is good to divide the film into frames by mounting special stickers on the film (Ask the PANI - support staff for details). Each sticker marks the beginning of a new frame and the scroller control calculates and divides the area between two marks into 65536 steps. So the narrower the marks the higher the precision. If you use no frames, the scroller takes the whole length of the film (max. 13m) for calculation. This results in a repeatable precision of positioning of at least 0.19mm, which should be enough for standard uses. (see more about frames in chapter 5 on page 10)

## 4.2) Communication Area

Here you find all information of the scroller status (LCD-display and LED-controls), the keys for basic settings and manual drive as well as the sockets of the main connections for standard uses.

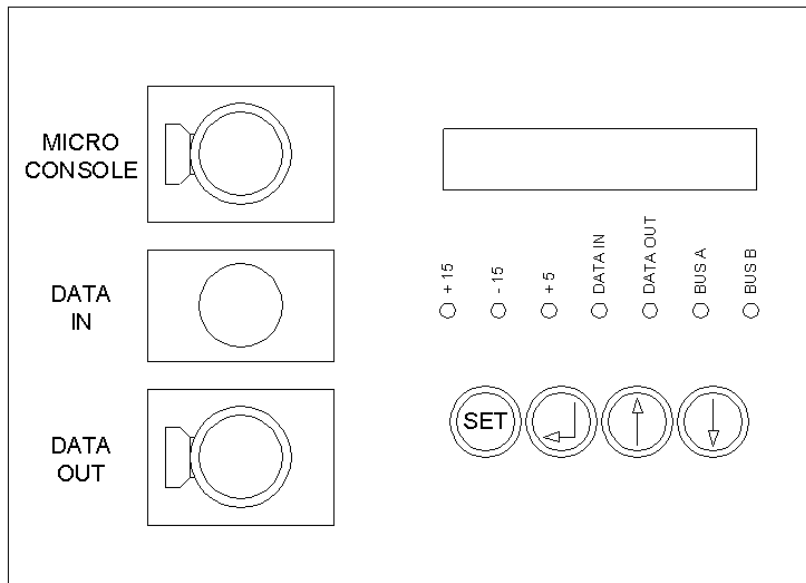

### The Menu Buttons and their functions:

Use	<b>SET</b>	to :	<b>enter</b> or <b>validate</b>
	←	to :	<b>leave</b> or <b>cancel</b>
	↑	to :	<b>change up</b> or <b>increase the value</b>
	↓	to :	<b>change down</b> or <b>decrease the value</b>

IF YOU PUSH THE 4 KEYS AT THE SAME TIME, YOU RESET THE UNIT !

The **7 LED** indicate the status of the power supply units and the data flow of the control unit of the scroller. These informations are mainly used for service purposes.

The standard 5-pin XLR sockets **DATA IN** and **DATA OUT** are for connecting the scroller with the DMX-console and for cascading scroller units for DMX-operation and standalone working (up to 4 units). You can use the standard male/female 5-pin XLR cables to connect. The DATA IN socket is also used for the connection of the scroller with the PC-interface, which is delivered with the optional deliverable PC-software. This software enables programming the built in EEPROM for standalone working and MIDI – synchronisation.

The 6-pin XLR socket **MICRO CONSOLE** is provided for special service operations only.

### The LCD-display:

After switching on the scroller it first runs a reset and self checking procedure, which is good to prevent an undefined status and unwanted reactions.

After finishing this check with a good result, the display automatically shows the main menu. This and a lot of submenus are shown in the logical diagram on pages 7 to 9.

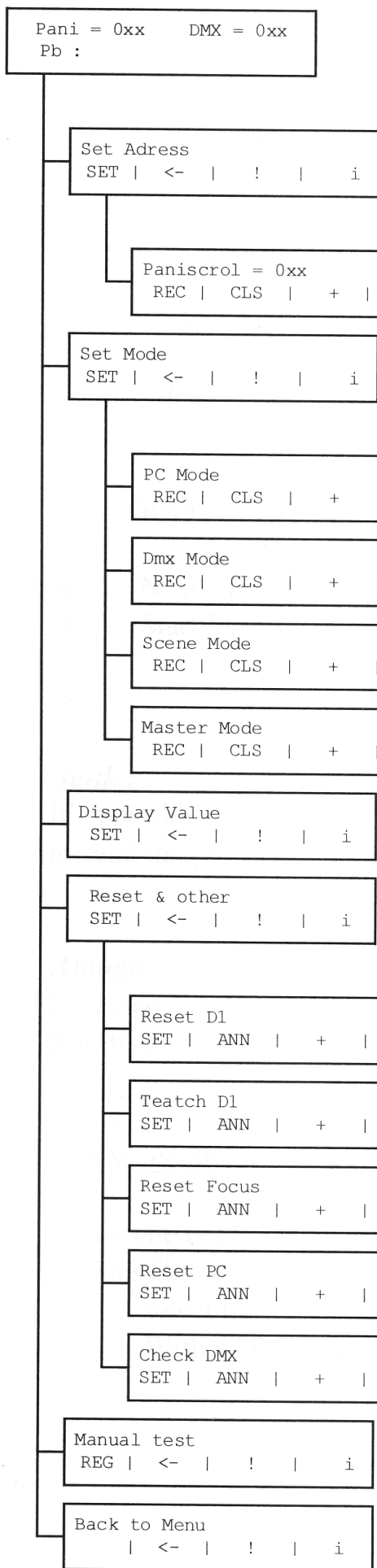

**At main :** press **Set** to go into the menu  
 Press ← to leave the menu  
 Press ↓ to toggle display value on/off

**Address Menu**

With these setting options, you can define the No of the scroller and the corresponding DMX address

**In Pani Scene Mode you can select the full DMX address 1 - 512**

**Mode Menu**

Here you define the actual working mode:

- **DMX-Mode:** The scroller is ready to be controlled by at most 11 DMX channels (see also 4.3)
- PC-Mode:** not supported anymore
- Scene Mode:** not supported anymore
- Master Mode:** not supported anymore

**Display Menu**

Here you can monitor the incoming data from DMX in real time.

You choose the parameter and press REC and after go back to main

When you don't want display, you go to the « display menu » and choose » Not »

**Reset and others**

In this menu, you can *reset* the scroller to leave an undefined driver status

Run the « *teach me* » process to read all film data (length, frame positions) into the flash memory of the scroller. This function is necessary when you change the film.

You can also *check the DMX* signal to know how many packages by second you receive.



```
Manual test
REG | <- | ! | i
```

```
Reglage DIM
REG | ANN | + | -
```

```
Reglage D1
REG | ANN | + | -
```

```
Reglage F1
REG | ANN | + | -
```

```
Reglage S1
REG | ANN | + | -
```

```
Reglage T1
REG | ANN | + | -
```

```
Reglage FOC
REG | ANN | + | -
```

```
Reglage CYA
REG | ANN | + | -
```

```
Reglage MAG
REG | ANN | + | -
```

```
Reglage YEL
REG | ANN | + | -
```

**Manual test.**

This function works duly when you unplug DMX!  
 Choose the parameter, which you want to test and press SET (=REG)  
 After that you can use 0/Full key (=min / max)  
 Or use ← to change the key step to 0FL  
 +16 / -16  
 +1 / -1  
 With the keys ↑ and ↓ you step through the values.  
 The scroller is following the new settings after confirming with SET.

**4.3) DMX-512 standard protocol**

The Compact Scroller CS-70 is normally provided for DMX-use. Some parameters are predefined, so you find here the tables to get the facility of programming:

Table of used DMX-Channels

Channel	Sign Notation	Description
1	D1	define position low res. (=coarse)
2	D2	define position high res. (=fine)
3	F	frame
4	S	driving speed
5	T	driving time
6	Dim	dimming shutter 1
7	Ign	projector ignition (reserved)
8	Foc	Focus
9		reserved for future functions
10		reserved for future functions
11		reserved for future functions

**User Tip:** Always set channel 4 at min. 2% to avoid malfunctions!

Mapping to define working area of DMX-channels for a greater number of scrollers:

Num.	DMX	Num.	DMX	Num.	DMX	Num.	DMX	Num.	DMX
1	1	8	78	15	155	22	232	29	309
2	12	9	89	16	166	23	243	30	320
3	23	10	100	17	177	24	254	31	331
4	34	11	111	18	188	25	265	32	342
5	45	12	122	19	199	26	276	-	-
6	56	13	133	20	210	27	287	-	-
7	67	14	144	21	221	28	298		

#### 4.4) The PC Mode and Automatic

**This Mode is not supported by PANI anymore.**

**Please use other solutions for DMX-standalone driving.**

#### 4.5) The PANI Scene Mode

**This Mode is not supported by PANI anymore.**

**Please use other solutions for DMX-standalone driving.**

## 5) Using Frames

### 5.1) General Information about Frames

The frame system allows you to divide a film into different zones with the advantage to reach more precision of film positioning (possibility for frames up to the number of 32)

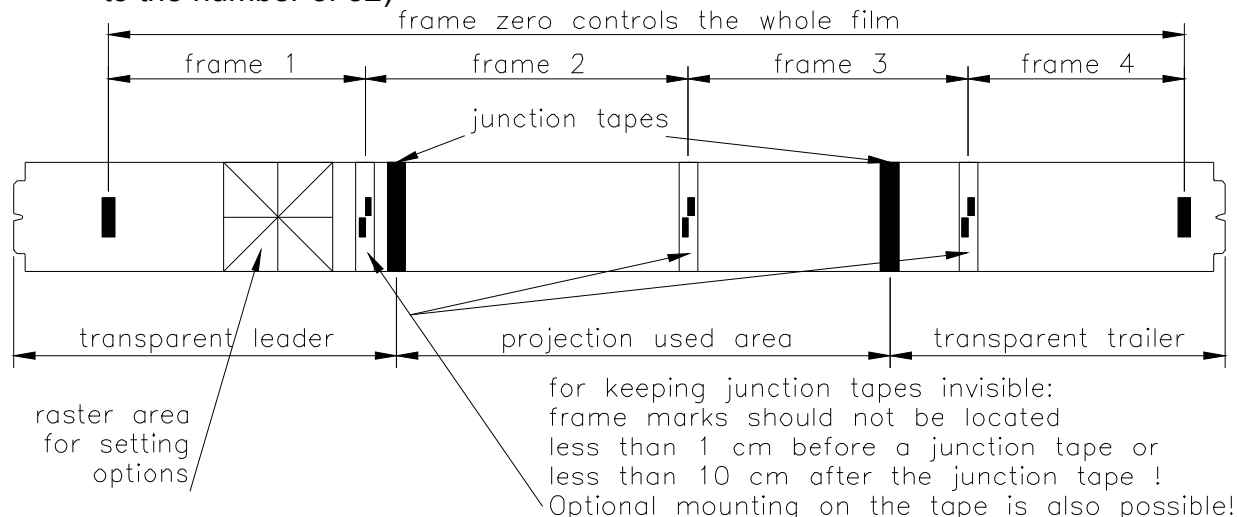

### 5.2) Controlling Frames

DMX-channel 3 (F) controls the frames:

Value 0 to 7 .... frame zero:

controls the whole film even if you have set some marks

Value 8 to 15 ... frame one:

controls the film between mark 1 and mark 2

other values see the following table:

#### DMX-settings for using frames:

Table for frame position values (binary and %)

Bin	Frame Num.	%	Bin	Frame Num.	%	Bin	Frame Num.	%
0 to 7	0	0	88 to 95	11	36	176 to 183	22	70
8 to 15	1	4	96 to 103	12	39	184 to 191	23	74
16 to 23	2	8	104 to 111	13	42	192 to 199	24	77
24 to 31	3	11	112 to 119	14	45	200 to 207	25	80
32 to 39	4	14	120 to 127	15	48	208 to 215	26	83
40 to 47	5	17	128 to 135	16	52	216 to 223	27	86
48 to 55	6	20	136 to 143	17	55	224 to 231	28	89
56 to 63	7	23	144 to 151	18	58	132 to 239	29	92
64 to 71	8	27	152 to 159	19	61	240 to 247	30	96
72 to 79	9	30	160 to 167	20	64	248 to 255	31	99
80 to 87	10	33	168 to 175	21	67			

- User Tips:**
- 1) Always use one single command for frames select (do not combine e.g. with position)
  - 2) Always use a step command for frames select (no fading)
  - 3) Always use the frames in increasing order to avoid malfunction and keep accuracy



### 5.3) Marks on the Film

Marks on the film are made of a piece of very thin high reflective adhesive tape, with a special shape print on it (5 samples are delivered with the scroller). Each mark indicates the beginning of the following frame, which ends at the next mark.

For positioning the distance between the two marks is divided into 65536 steps. So the accuracy of positioning depends on the distance of the marks. But the best precision is 0,05 mm max. because of the limits of the optical sensor.

**Note:** 1) For keeping junction tapes invisible: Do not position marks less than *1 cm before* or *10 cm after* a tape or optionally position it on the tape.  
2) Position the mark at that side of the film, which is inside the scroller unit to read it with the optical sensor.

The positions of the frames are learned by the scroller during the function "teach me" (see chapters 4.2 page 7 and 5.4 on this page)

### 5.4) Frames in Use

The positioning of a film with frames is depending on the three DMX-channels 1,2 and 3. So if you change only the frame parameter, the film runs to the set position of the new frame.

Please note the User Tips on pages 8 and 10 !

## 6) The Scroller Module (Cassette)

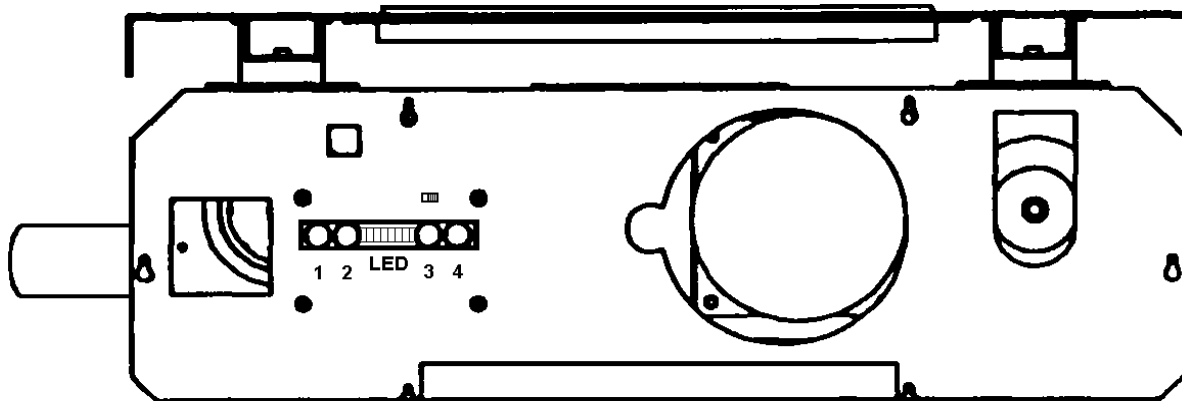

On top of the Scroller cassette you find the LED – bank and 4 keys.

<b>LED:</b>	2 red	Scroller encoder: blinks during the moving of the film
	2 yellow	electric source $\pm 15V$ must light up permanently
	2 green	frame sensor, lights up, when frame indicator is present in the sensor-position
	2 yellow	1 of them is light up, when the scroller cassette gets data from the electronic control unit.
<b>Keys:</b>	2 red	Not in use
	Num. 1	to drive the film manually left, press key Num. 2 additionally for forcing the driving speed
	Num. 2	to drive the film manually right, press key Num. 1 additionally for forcing the driving speed
	Num. 3 and 4	pressing together says "teach me" Pressing all 4 keys together results in a reset run.

***For loading the film into the Cassette, see delivered QUICK REFERENCE !***

## 7) Basic Unit as Delivered

- 1 CS-70 housing unit with built in universal fan, electronic drive equipment and added mask holder
- 1 CS-70 cassette unit with built in electronic drive equipment and loaded standard film ends  
(mounted and fixed in the housing unit)
- 1 supporting rod and a connection block
- 4 set of accessory bearing rods (supporting all focal lengths up to 60cm)
- 1 standard lens mounting set
- 1 lens mounting ring for 11 and 13,5 cm lenses
- 2 lens adapter tube
- 3 lens adapter rings
- 4 adapter brackets for BP 6
- 1 adapter plate for BP 2,5 and 4 (mounted with 4 wing nuts on the housing unit)
- 1 PCS-adapter unit
- 1 XLR 3-pin connecting cable 2m (for dimmer)
- 1 bag with: 4 screws for mounting the adapter plate on BP 2,5 or 4  
1 screw with spring washer and hexagonal nut ( see 3.2) 2 )  
1 dummy plug for BP 2,5 and 4
- 5 pcs. of PANI - frame marks
- 1 instruction manual
- 1 quick reference for loading the film

## 8) Accessories

Description	Type:	Order Code:
CS-70 cassette unit for simple changing the scroller repertoire		12521
CS-70 film cutting & gluing device for exact preparing the film		12813
CS-70 motor driven focus unit for DMX- or programme- driven focusing		12045
PANI - frame marks for CS-70		4423

This list will be continued

For actual information please see our homepage or contact us:

**<http://www.pani.com>**

**e-mail: [light@pani.com](mailto:light@pani.com)**

## 9) Technical Data

### Mechanical Data

<b>Size of Housing</b> (L x W x H)	554 x 515 x 700 mm
<b>Size of Cassette</b> (L x W x H)	170 x 480 x 385 mm
<b>Weight Housing</b>	17 kg
<b>Weight Cassette</b>	13 kg

### Film Data

<b>Slide Format</b> (= free masking frame format):	180 x 155mm
<b>Film dimensions:</b>	max. 13 m x max. 180 mm
<b>Best film width for good function:</b>	175-178mm
<b>Max. Number of Single Slides</b> (180x155)	72

### Driving Speeds:

maximum:	0,28 cm/s = 16 m/min	at the beginning of the film
	0,42 cm/s = 25 m/min	near the end of a 13m long film
minimum:	0,11 mm/s = 6,6 mm/min = 0,39 m/hour	

### Accuracy:

minimum without frames with a film length of 13m:	0,19mm
maximum with frames up to 3,3m length	0,05mm

### Electrical Data

<b>Supply Data</b>	220/240V – 50 Hz, 2A(nom.), 3A (fuse)
<b>Protection Class:</b>	IP 20
<b>Fan Capability:</b>	430 m <sup>3</sup> /hour
<b>Cable:</b>	2 m with Schuko connector

### Application Fields

<b>PANI-Compatibility</b>	BP2500Halogen and BP3000Halogen BP 2,5 Compact and BP 2,5 CT BP 4 Compact and BP 4 CT BP 6 Gold II (with new universal filter) BP 6 GT others on request
---------------------------	---

<b>Rotation on Projector</b> (around optical axis)	± 90° possible
<b>Ambient Operating Temperature:</b>	max. 30°



## Pani Projection and Lighting Vertriebs GmbH

AUSTRIA – EUROPE  
A-1070 VIENNA, KANDLGASSE 23

TEL. + 43 1 521 08-0\*  
<http://www.pani.com>

FAX + 43 1 526 42 87  
e-mail: [light@pani.com](mailto:light@pani.com)